



PLASTIC CART ASSEMBLY INSTRUCTIONS

UCPL1, WE, WT • 2-Shelf Models

Table of Contents

Cart Assembly

Page 2 2-Shelf Plastic Cart Assembly Instructions

Optional Accessories

Page 3 Cabinet Installation Instructions
Page 4 Locking Drawer Installation Instructions
Page 5 Pullout Keyboard Tray Installation Instructions
Page 6 Power Strip & Cord Wrap Installation Instructions

NOTE: *This guide includes instructions that may not be applicable to your specific model. Each cart will ship with assembly instructions for the cart and included accessories only. Instructions for accessories will be packaged with each accessory's respective components.*

PARTS KEY:

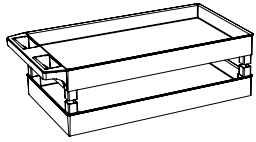

A x 1 Top
B x 1 Bottom

Tub Shelves*
(SEC, EC, STC, and TC models)

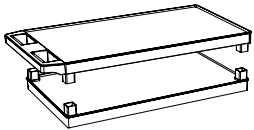

A x 1 Top
B x 1 Bottom

Flat Shelves*
(EC, HE, HC, LE, LP, and WT models)

4" Standard Casters

C x 2

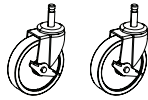

Locking Casters

D x 2

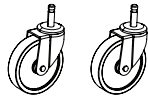

Non-Locking Casters

E x 4

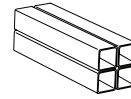

Square Legs
(WT, SEC, and EC models)

OR

E x 4

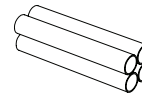

Round Legs
(LE, LP, STC, TC, and BC models)

REQUIRED TOOLS:

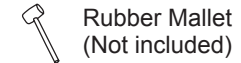

IMPORTANT:

If your cart includes options such as a power strip, pullout shelf, locking drawer, or locking cabinet, installation instructions for those components will be included in their packaging.

*NOTE:

Some EC, STC, and TC models come with a mix of flat and tub shelves.

ASSEMBLY INSTRUCTIONS:

1

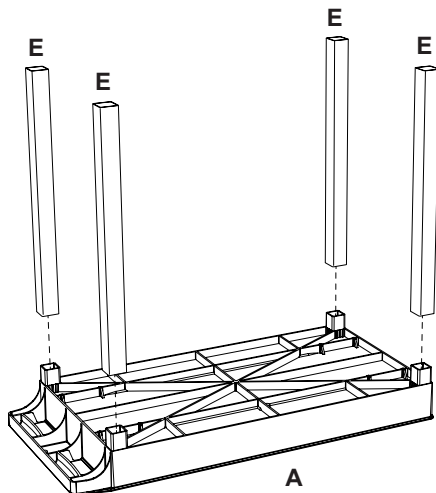

2

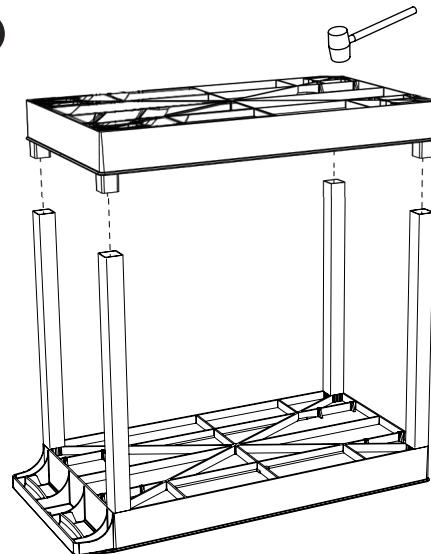

3

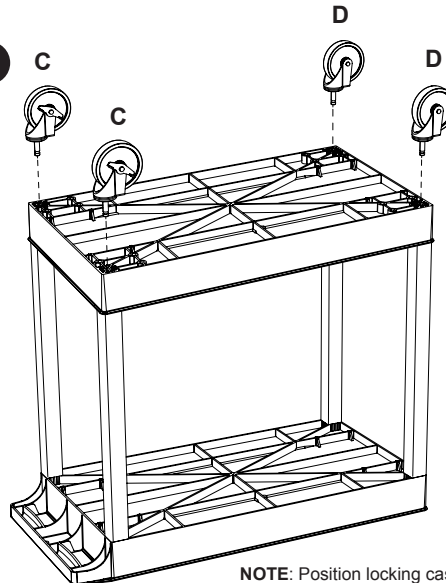

NOTE: Position locking casters (C) on the same end as the handle.

4

Flip the unit upright after casters are securely installed.

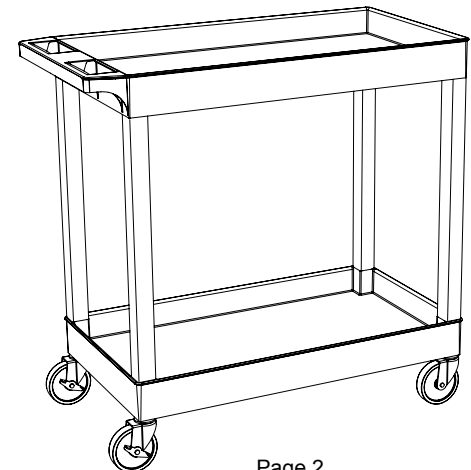

Parts List

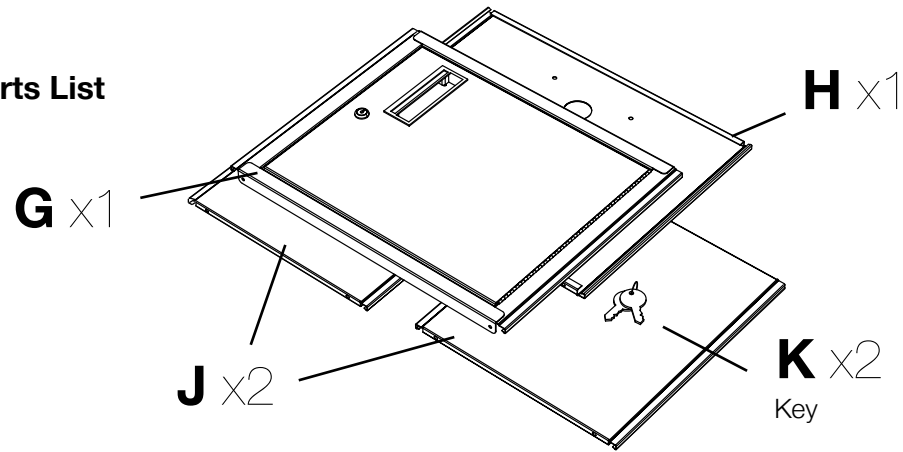

Tools Required

- Rubber Mallet

Tuffy Cart Cabinet Pack Instructions

Please consult your Tuffy cart base unit instructions before starting

- 1** **IMPORTANT:** Flip shelf **B**, and lock the 2 locking casters **D** before assembling the unit.

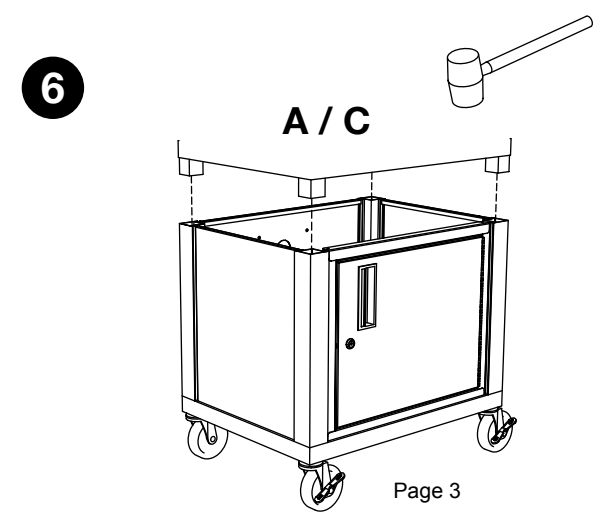
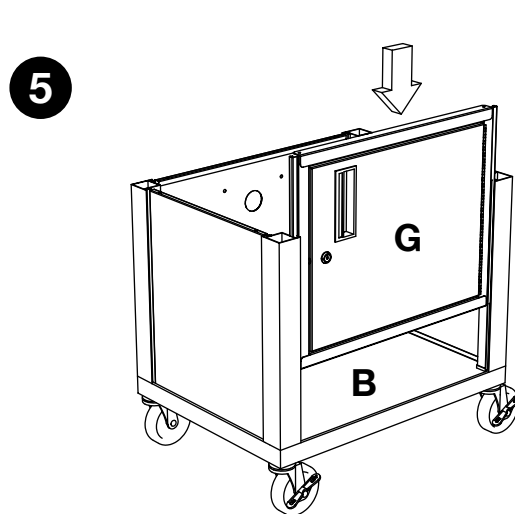
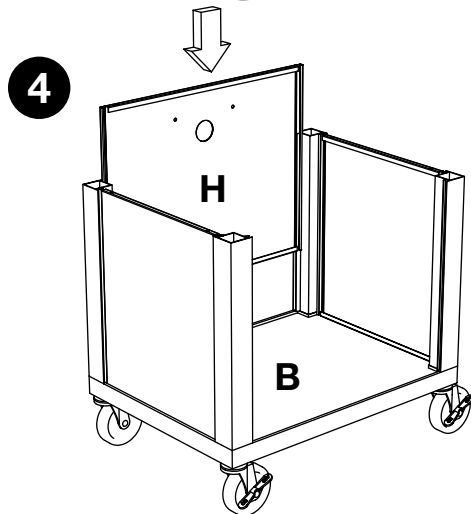
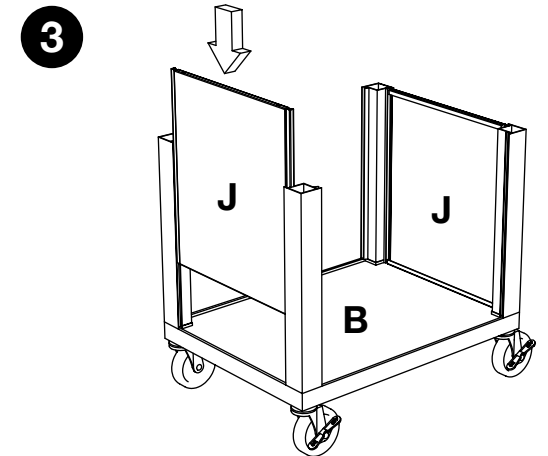
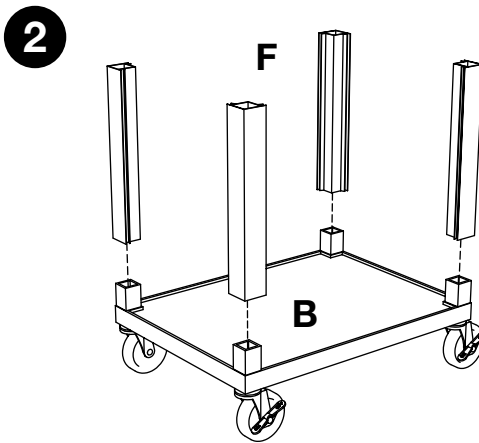
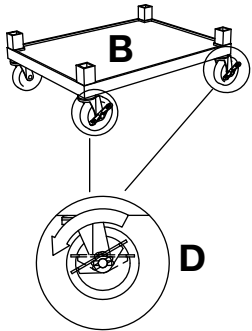

Parts List

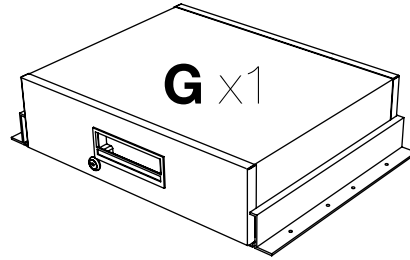

Tools Required

- Phillips Screwdriver

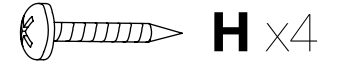

1

With a Phillips Screwdriver, attach the drawer assembly to the top shelf with the 4 screws.

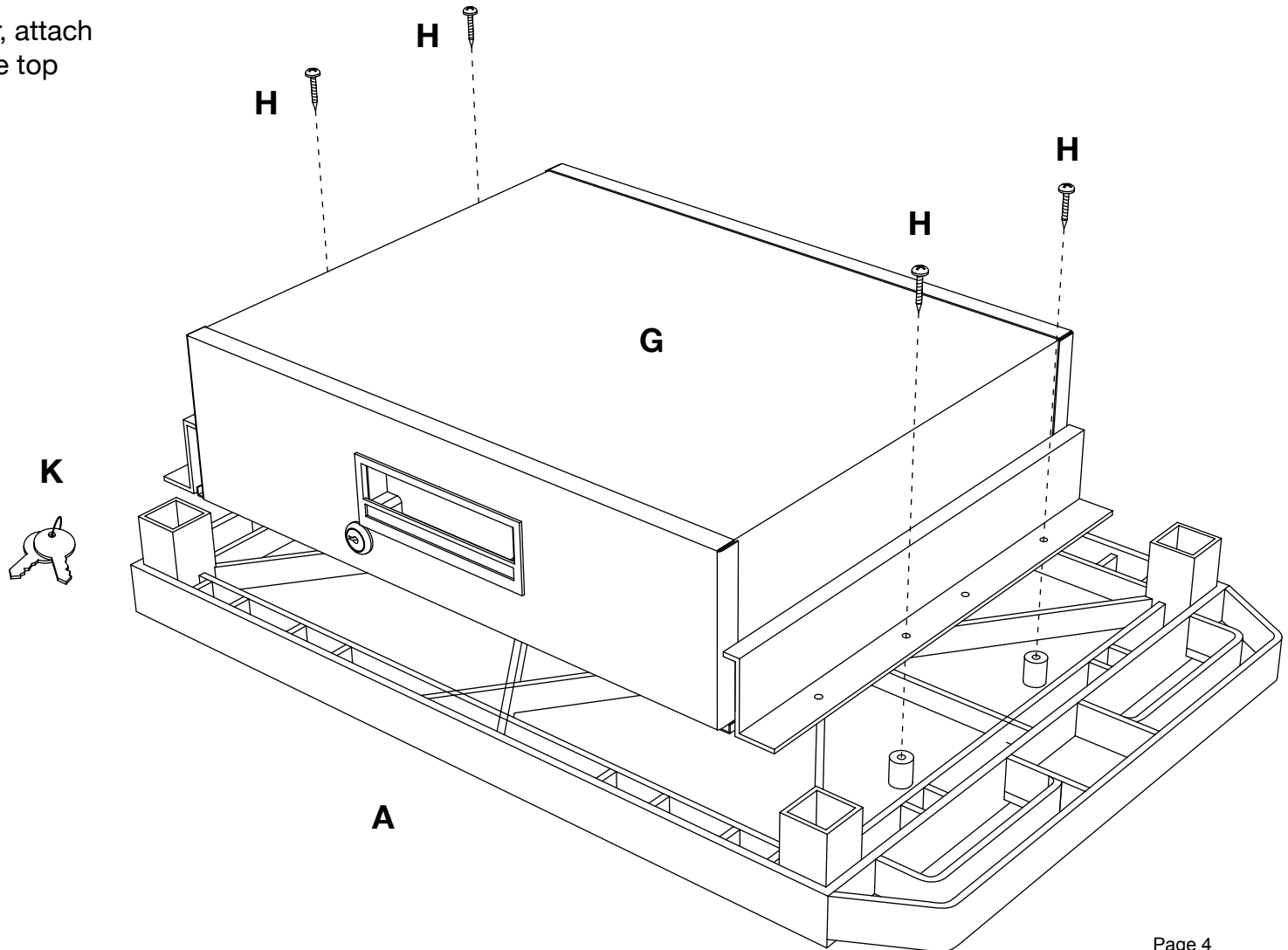

Parts List

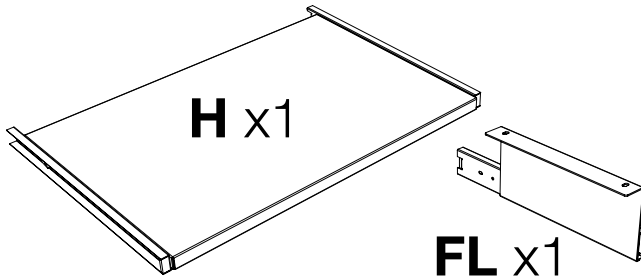

Tools Required

- Phillips Screwdriver



NOTICE:

Size and style of the plastic ribbed shelf may vary by model number.

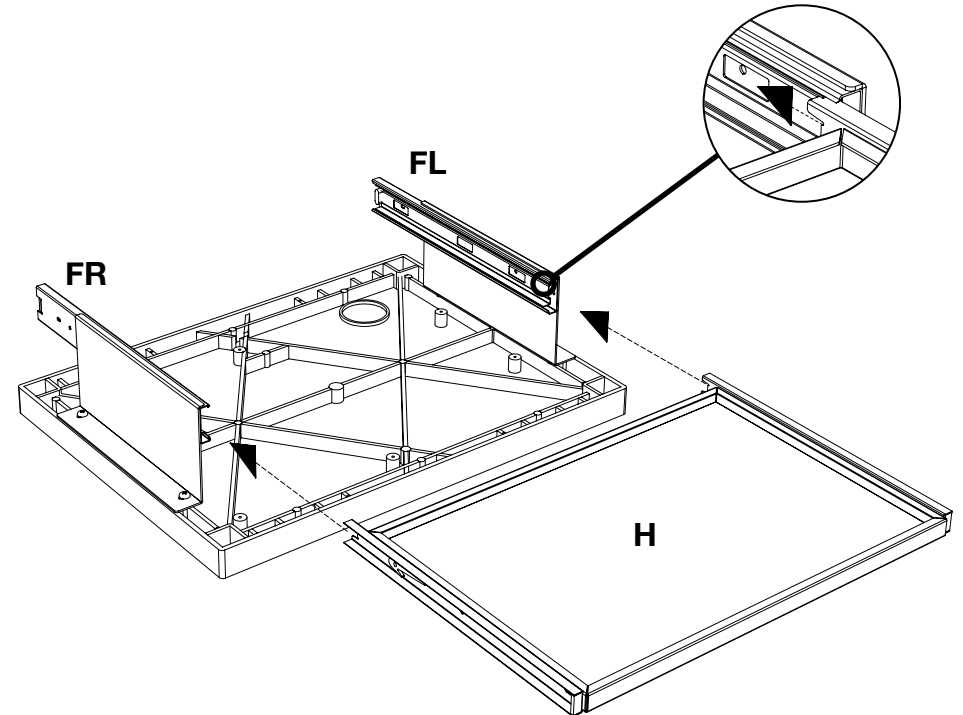
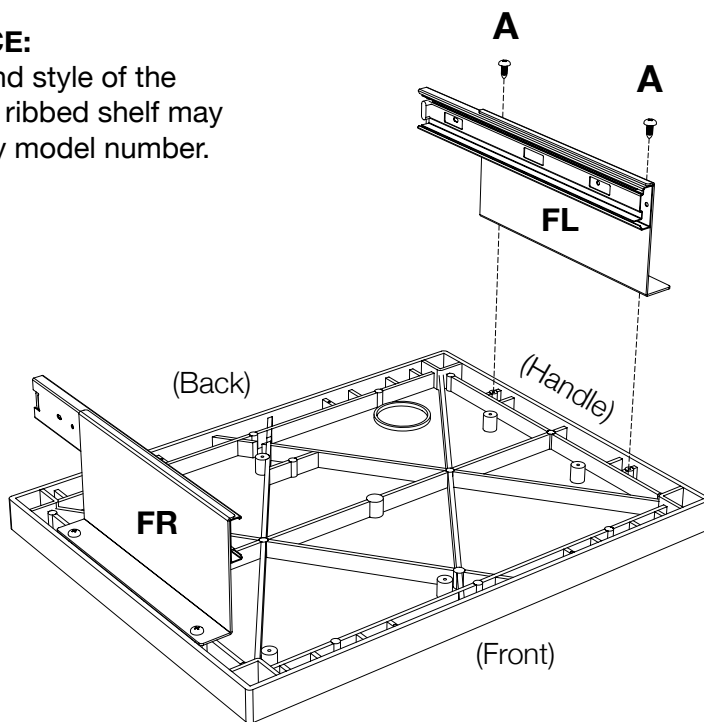

Take the top shelf of your plastic cart and lay it flat. Collect parts: **FL**, **FR** & **A**. Align **FR** & **FL** to the outer holes at the top of the shelf. Take screw **A** and fasten with a screwdriver, do not tighten fully until keyboard is attached.

Collect parts: **H**. Align the pullout shelf **H** runner so that the runner snaps into place into the **FL** & **FR** brackets. Pull the shelf out to make sure it is fully seated. Tighten screws **A**. Pullout keyboard shelf assembly is now complete.

Electric Assembly Instructions

Number of outlets may vary.

Parts List

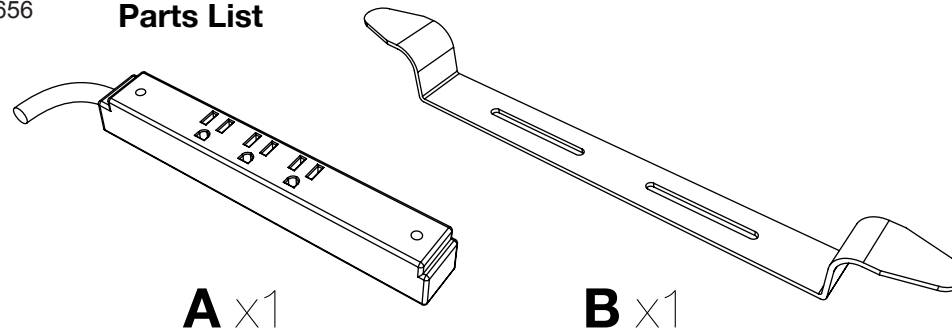

Tools Required

- Screwdriver

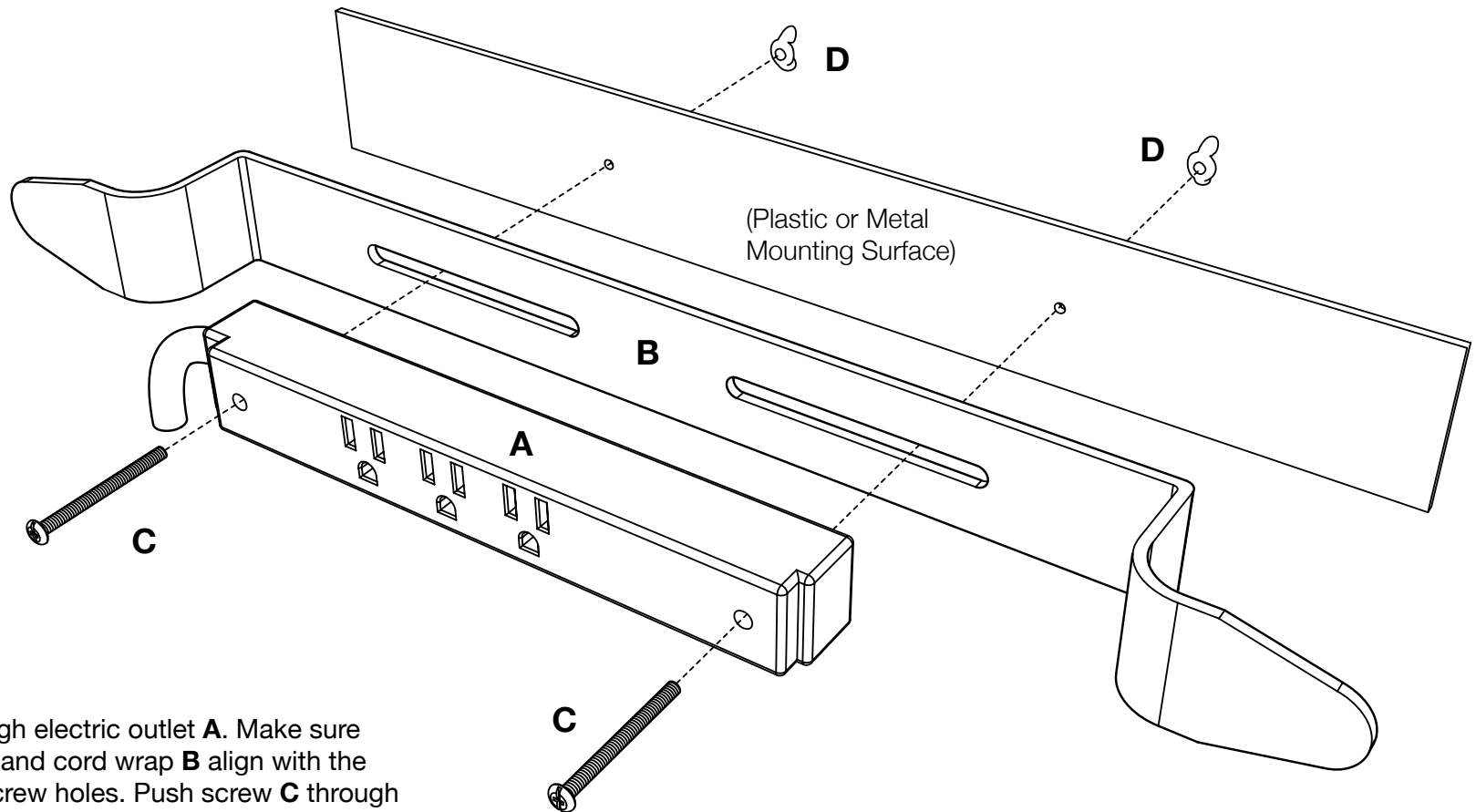
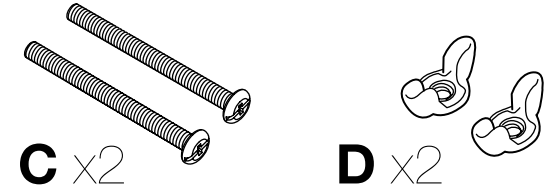

1

Push screw **C** through electric outlet **A**. Make sure the electric outlet **A** and cord wrap **B** align with the mounting surface screw holes. Push screw **C** through cord wrap **B** and the mounting surface screw holes. Use wing nut **D** and screwdriver to fasten.